

ELECTRIC RIDERS

Electric Lift Trucks
Superelastic Tires

GEX16
GEX18
GEX20s

1600 kg
1800 kg
2000 kg

GEX16/18/20s

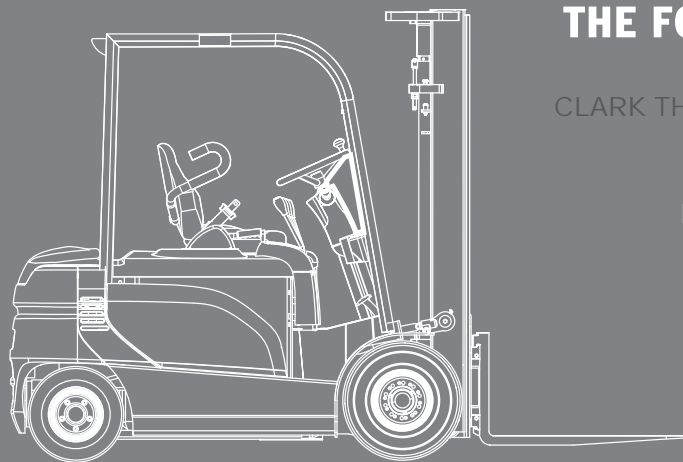

CLARK
THE FORKLIFT

CLARK THE FORKLIFT

Europe

North Amerika

South Korea

w w w . c l a r k m h e u . c o m

GEX16/18/20s

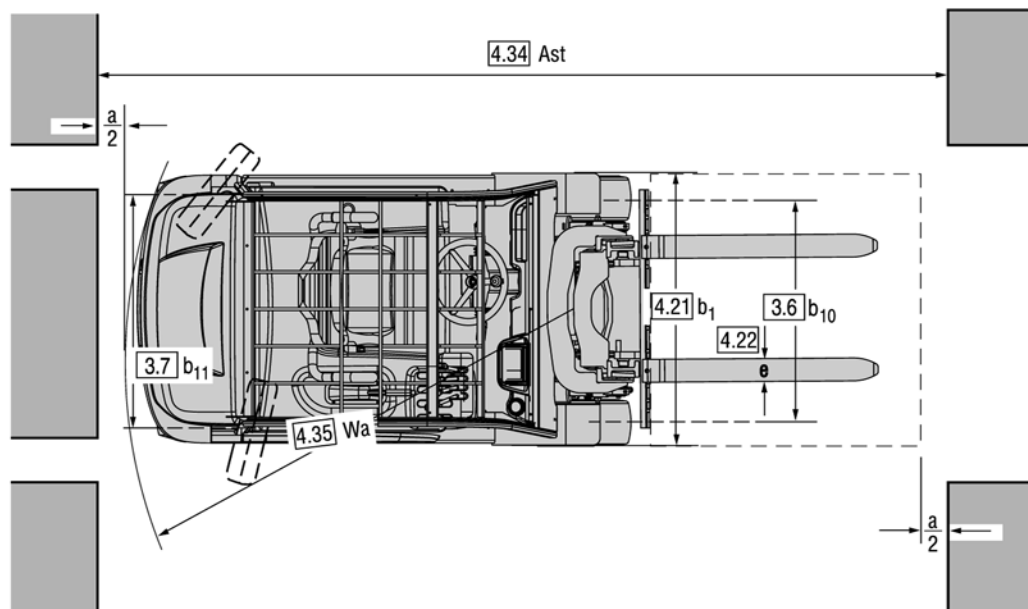
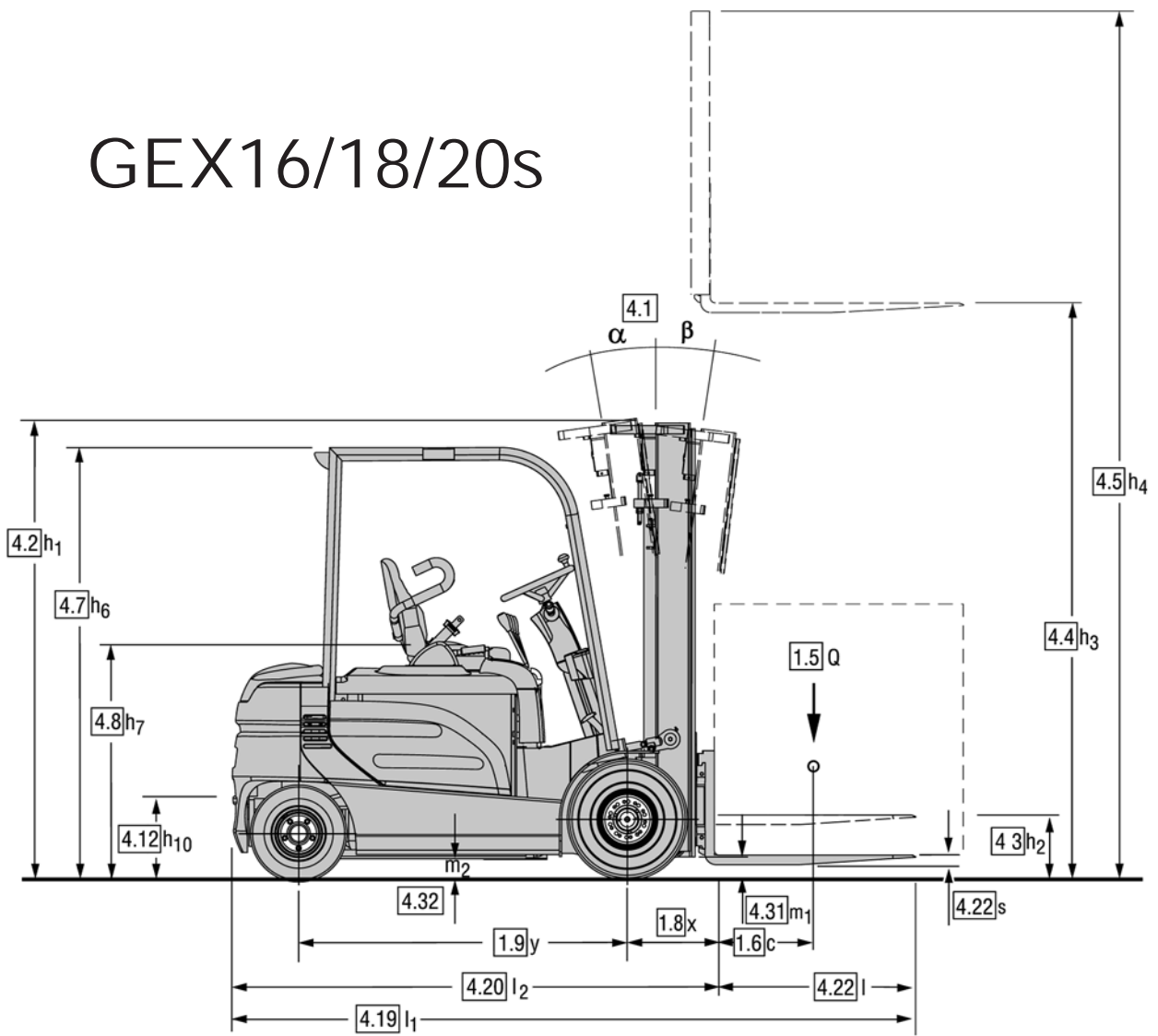

$$A_{st} = W_a + x + b + a$$

$$a = 200 \text{ mm (safety distance)}$$

For data see corresponding number in chart "Product Specifications".

DIMENSIONS

Performance may vary +5% and - 10% due to motor and system efficiency tolerance. The performance shown represents nominal values which may be obtained under typical operating conditions of a machine. CLARK products and specifications are subject to change without notice.

Truck Capacities

Capacity at different load centres

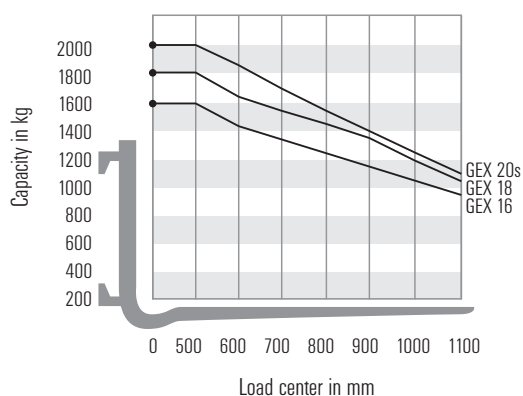

Note:

The listed capacities are valid only for the standard upright in vertical position with standard fork carriage and standard forks, up to max. lifting height of 3085 mm. The centre of gravity of the load may be displaced by max. 100 mm against the longitudinal centre plane of the truck. Load centre is determined from top and front face of the forks. The values are based on a 1000 mm cube load configuration with the centre of gravity at the true centre of the cube. With upright tilted forward lower capacity values are valid. Attachments, longer forks, exceptional load dimensions and higher lifting heights can reduce the capacity. Please talk to your CLARK dealer if you require further information.

Upright table

Capacity at different load centres

Upright table metrics in mm

CLARK Ref.	max. fork height h3	overall height lowered h1	free lift h2h5*
------------	---------------------	---------------------------	-----------------

Standard GEX 16, 18, 20s

(2 Stage Mast, standard free lift)

V	2085	1560	132
V	2585	1810	132
V	2785	1905	132
V	3085	2060	132
V	3385	2205	132
V	3585	2310	132
V	3795	2415	132
V	4075	2555	132
V	4585	3010	132
V	5085	3260	132

* without LBR

Upright table metrics in mm

CLARK Ref.	max. fork height h3	overall height lowered h1	free lift h2h5*
------------	---------------------	---------------------------	-----------------

Triple GEX 16, 18, 20s

(3 Stage Mast, full free lift)

M	3970	1835	597
M	4345	1960	722
M	4780	2105	867
M	5185	2255	1017
M	5565	2415	1177
M	5740	2480	1242
M	6015	2605	1367
M	6470	2795	1557
M	7075	3050	1812

* without LBR

Upright table metrics in mm

CLARK Ref.	max. fork height h3	overall height lowered h1	free lift h2h5*
------------	---------------------	---------------------------	-----------------

Hi-Lo GEX 16, 18, 20s

(2 Stage Mast, full free lift)

H	2925	1960	722
H	3215	2105	867
H	3515	2255	1017
H	3695	2345	1107
H	3810	2415	1177

* without LBR

Product Specifications

nach VDI 2198

	1.1 Manufacturer (Abbreviation)		CLARK	CLARK	CLARK	
Specifications	1.2 Manufacturer's designation		GEX16	GEX18	GEX20s	
	1.3 Drive unit battery		Elec-48V	Elec-48V	Elec-48V	
	1.4 Operator type stand on/ driver seated		Rider-seated	Rider-seated	Rider-seated	
	1.5 Load capacity/ rated load	Q (kg)	1600	1800	2000	
	1.6 Load centre distance	c (mm)	500	500	500	
	1.8 Load centre distance, centre of drive axle to fork face	x (mm)	358	358	358	
	1.9 Wheelbase	y (mm)	1312	1420	1420	
	Weight	2.1 Service weight	kg	3132	3235	3409
		2.2 Axle loading, laden front/ rear	kg	3979/753	4373/662	4759/650
2.3 Axle loading, unladen front/ rear		kg	1416/1716	1490/1745	1559/1850	
Tires, Chassis	3.1 Tyre type, SE = superelastic, C = cushion		SE	SE	SE	
	3.2 Tyre size, front, superelastic		17x7-8	18x7-8	200/50-10	
	3.3 Tyre size, rear, superelastic		15x4.5x8	15x4.5x8	15x4.5x8	
	3.5 Wheels, number front/ rear (x = drive wheels)		2x/2	2x/2	2x/2	
	3.6 Tread, front SE (C)	b ₁₀ (mm)	905	905	915	
	3.7 Tread, rear	b ₁₁ (mm)	870	870	870	
	Dimensions	4.1 Tilt of upright/ fork carriage, a/ b	deg	6/6	6/6	6/6
4.2 Height, upright lowered		h ₁ (mm)	2060	2060	2060	
4.3 Freelif		h ₂ (mm)	132	132	132	
4.4 Lift height		h ₃ (mm)	3085	3085	3085	
4.5 Height, upright extended		h ₄ (mm)	4323	4323	4323	
4.7 Height overheadguard (Container)		h ₆ (mm)	2055	2055	2059	
4.8 Seat height MSG 20 (MSG 12)		(mm)	856	856	856	
4.12 Coupling height		(mm)	351	351	351	
4.19 Overall length		l ₁ (mm)	3048	3156	3156	
4.20 Length to face of forks		l ₂ (mm)	1978	2086	2086	
4.21 Width		b ₁ (mm)	1059	1059	1122	
4.22 Fork dimensions		s*e*l (mm)	40x100x1070	40x100x1070	40x100x1070	
4.23 Fork carriage DIN 15173, A, B			CL II A	CL II A	CL II A	
4.24 Fork carriage width		b ₃ (mm)	940	940	940	
4.31 Ground clearance minimum, laden		m ₁ (mm)	85	85	85	
4.32 Ground clearance centre of wheelbase		m ₂ (mm)	84	84	87	
4.34 Stacking aisle for pallets (l ₆ -b ₁₂) 800 x 1200 across		(mm)	2941	2941	2941	
4.34 Stacking aisle for pallets (l ₆ -b ₁₂) 1000 x 1200 across	(mm)	3121	3121	3121		
4.34 Stacking aisle for pallets (l ₆ -b ₁₂) 800 x 1200 along	(mm)	3245	3245	3245		
4.35 Turning radius	W ₃ (mm)	1638	1746	1746		
Performance	5.1 Travel speed laden/ unladen	km/h	15/16	15/16	15/16	
	5.2 Lift speed laden/ unladen	m/s	0.40/0.50	0.37/0.50	0.35/0.50	
	5.3 Lowering speed laden/ unladen	m/s	0.57/0.52	0.57/0.52	0.57/0.52	
	5.5 Drawbar pull laden/ unladen (S2 60 min)	kg	742/1671	785/1674	747/1641	
	5.6 max. drawbar pull laden/ unladen (S2 5 min)	kg	1012/2038	1122/1918	883/1740	
	5.7 Gradeability laden/ unladen (S2 30 min)	%	23.4/37.7	24.1/35.2	24.0/31.8	
	5.8 max. gradeability laden/ unladen (S2 5 min)	%	27.0/41.5	29.0/35.5	26.2/34.0	
	5.9 Acceleration time laden/ unladen (0 - 10 m)	sec	4.84/5.23	5.1/5.3	4.80/5.26	
	Drive Line	6.1 Drive motor rating (S2 60 min)	kW	2x4.4	2x4.4	2x4.4
6.2 Lift motorrating (S3 15 %)		kW	15.2	15.2	15.2	
Miscellaneous	8.1 Type of control		AC/Invertor	AC/Invertor	AC/Invertor	
	8.2 Operating pressure for attachments	kg/cm ²	158	158	158	
	8.4 Sound level, driver's ear	dB (A)	72	72	72	

Operator cell

- Driver oriented coloured TFT-LCD-display showing real time operating data
- Customised adjustment of 80 operating parameters to suit working conditions and drivers preference
- Input of parameters via intelligent display instead of expensive handset or notebook
- Generous foot space, simple and comfortable handling of pedals
- Easily accessible emergency switch
- Easy entry and exit as well as customised adjustment to the driver via tilting steer pylon
- Ergonomically designed workplace to suit 92.5 % of all operators
- Noise reduced hydraulic pump

Engines

- Dual drive motors which provide increased traction especially on wet or uneven surface
- Precise and dynamic response to lift- and tilt controls
- Optimisation of energy consumption
- Return of energy by regenerative braking
- All motors are completely enclosed and thus protected against dust, water and dirt
- Equipped with thermistor which constantly monitors temperature; control cuts back current when temperature approaches thermal limit

Brakes

- Continuous brake power by completely enclosed wet disk brakes – even in humid, abrasive or corrosive-prone environment
- No adjustment or regular replacement of the brake pads necessary

Steering

- 90° turn steer axle (GTX)
- 101° steer angle (GEX)
- Tightest possible turn radius as pivot point is centered between drive wheels
- Constant transmission of steering wheels position by sensor

Hydraulic system

- A single gear driven pump provides oil for hydraulic functions and steering
- Electro-hydraulic valves
- Gentle load handling thanks to sensitively operated and precisely responsive control valve
- Optional: Mini-Joystick-hydraulic controls integrated into armrest
- Optional: Mini-Lever-hydraulic controls integrated into armrest

Upright

- CLARK Standard-, Hi-Lo- and Triplex-full free lift uprights
- Extremely distortion resistant due to special rolled profiles
- Hydraulically shock absorbing lift cylinders ensure silent operation, especially during free lift
- Sealed canted rollers minimise deflection and free play in both upright and carriage
- Even distribution of load weight via six carriage rollers
- Robust chassis made of thick steel ensures high torsional chassis strength.

Additional features

- Fork leveller
- Video-Camera (rear, carriage)
- Unitrol
- Seat cutoff
- Automatic seat brake
- Incline limiter



CLARK Europe GmbH

Neckarstraße 37

D - 45478 Mülheim an der Ruhr

Tel. +49 208 377336 0

Fax +49 208 377336 36

email: info-europe@clarkmheu.com

www.clarkmheu.com

Your authorized CLARK dealer is: